

MAIN BEAM TO SUPPORT LEG ASSEMBLY

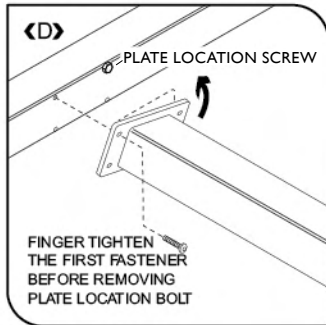

JOINING THE MAIN BEAMS

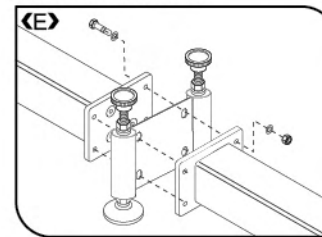

PACKAGING BOLT'S ASSEMBLY

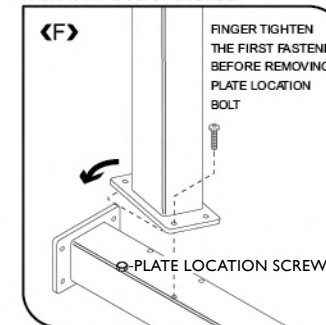

CONTENTS CHECK LIST

- 2 x Court Saver anchors
- 6 x Wheels (already attached)

- 2 x End beam with wheels 1.2m long
- 3 x Main beams 4m long

- 1 x Net
- 2 x Net Posts with lacing rods
- 2 x Post cap rollers and pins
- 1 x Net Winder Handle
- 1 x Centre Strap, fasteners and anchor

Fastenings listed below are pre installed:  
8 x M8 x 40 button socket screws } For attaching court savers to beams  
8 x Nyloc nuts  
16x M8 x 40 button head post & support leg screws, see D+F  
32 x M8 stainless washers

ATTACHING THE NET TO FIXED END POST

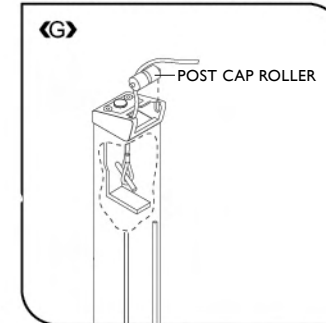

FRAME ASSEMBLY INSTRUCTIONS

- Remove all packaging and lay parts out in order
- Assemble main end beams to support legs Ref Diag <D>. **IMPORTANT** To insure internal plates don't move, remove all but one M8 button socket screw and washer when attaching the end. Once one is attached, remove the plate location screw and screw the remaining 3 button socket screws into place with washers

Repeat at the opposite end

- Attach the vertical net post Ref Diag <F>. Position the lacing rod facing the inside. Again to insure internal plates don't move, remove all but one M8 button socket screw and washer. Once one is attached, remove the plate location screw and screw the remaining 3 button socket screws into place

Repeat at the opposite end

- Wheel the ends into place and fasten to main centre beam with court savers inbetween Ref Diag <E> use M8 button socket screws and washers. Ensure the net strap hole on the centre beam is facing upwards.

- Ensure the structure is on level ground or positioned in desired playing position
- Ensure all screws between beams, posts and court savers are fully tightened

NET FITTING INSTRUCTIONS

- Fit the net cable to anchor hook inside the fixed end net post. Ref Diag <G> Use the Inspection hole to locate the anchor

- Fit the net cable to anchor hook inside winding end net post Ref Diag <H> Use the inspection hole to locate the anchor

- Lift the cable at each end and insert the post cap rollers

- Position net strap around top of net and secure with fasteners to the top of the main centre beam Ref Diag <I>

- Ensure all screws are tight prior to tensioning the net

- Insert the winding handle and tension the net until the net strap is fully extended. Increase the tension tow more turns.

WARNING: DO NOT OVER TENSION THE NET.

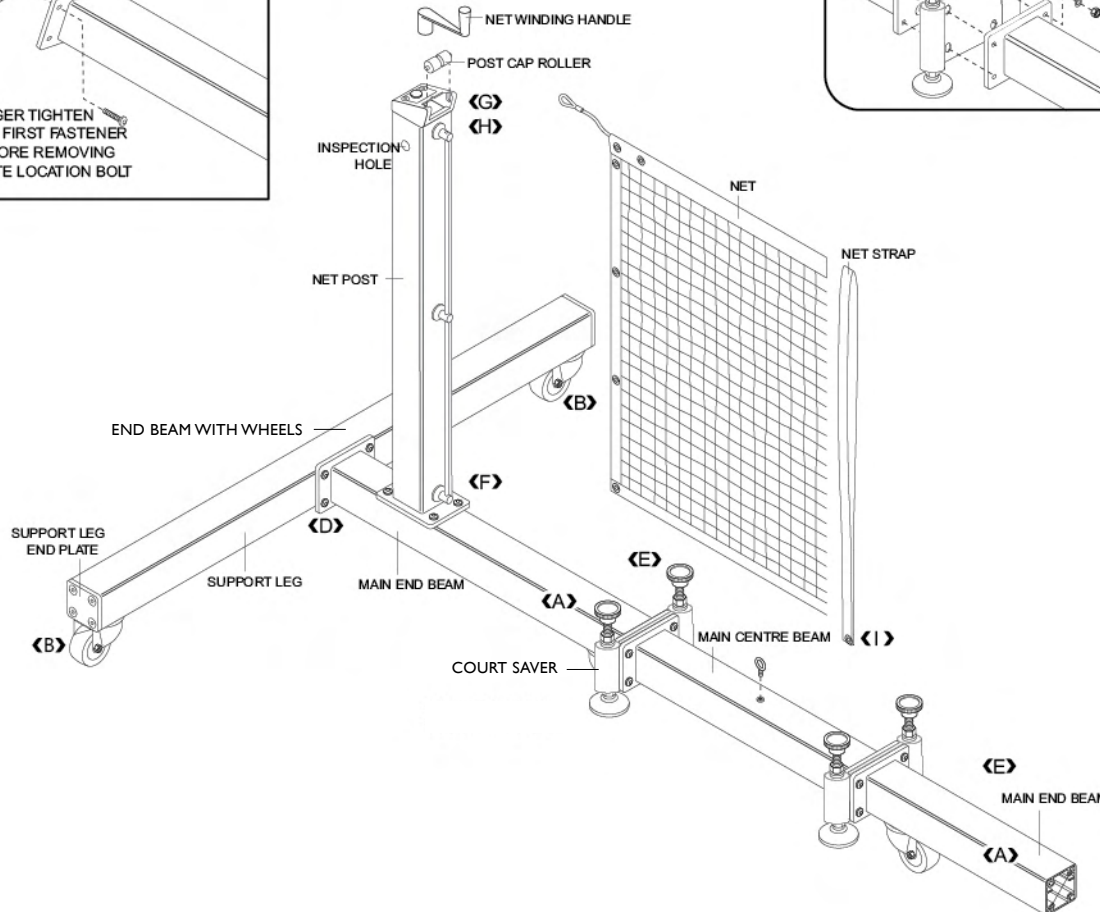

Excluding nets