

	PRODUCT SHEET		
	2 FOOTBALL GOALS, WITH REAR FRAME, DIMENSION 5x2m		
	PRODUCT REF	S12137	PAIR
			
DESCRIPTION			
Steel structure Ø90 Powder coated 5.00m x 2.00m			
CONFORM			
European norm EN 748			
ASSEMBLY TIME			
The assembly time for this goal is estimated at 30 minutes with 2 people (without footing).			
TEST AFTER INSTALLATION			
<p>According to the regulation above, this product has to be tested like below:</p> <ul style="list-style-type: none"> - Put 180kg at 20cm from the ground and in the middle of the crossbar for 1min. - Apply an horizontal force of 110 kg on the middle of the crossbar, by a 3 meter rope, for 1min. <p>After these tests, the equipment and the fixation system should not have break, move or show residual deformation.</p> <p>During the first installation, stability and strength tests are compulsory. Every time you install the equipment, a visual check of the stability and strength must be realized. The owner of this equipment must usually control the product.</p> <p>For an optimal use of our products, we advise to follow the installation and maintenance instructions.</p>			
MAINTENANCE			
<p>The equipment has to be regularly maintained by the owner. It is recommended to:</p> <ul style="list-style-type: none"> - Check every week that all the bolts are correctly tightened - Fix paint defects if the unit has been damaged, using the adapted paint specified by the manufacturer. - Replace all damaged or missing parts with a spare part recommended by the manufacturer. - Clean the product by using dishwasher soap, clean water, and soft cloth. 			
WARRANTY			
<p>One full year parts and labour guarantee. Every claim regarding the condition of the delivered equipment has to be done within the warranty period following receipt of the product.</p> <p>The warranty will not apply to:</p> <ul style="list-style-type: none"> - Any degradation during transport. - Any degradation due to poor maintenance. - Any degradation due to use differing from which the product was intended. - Any defect claimed after the end of the warranty period. - Any damage due to a faulty installation or assembly of the product. 			

FIXATION AND FOOTING

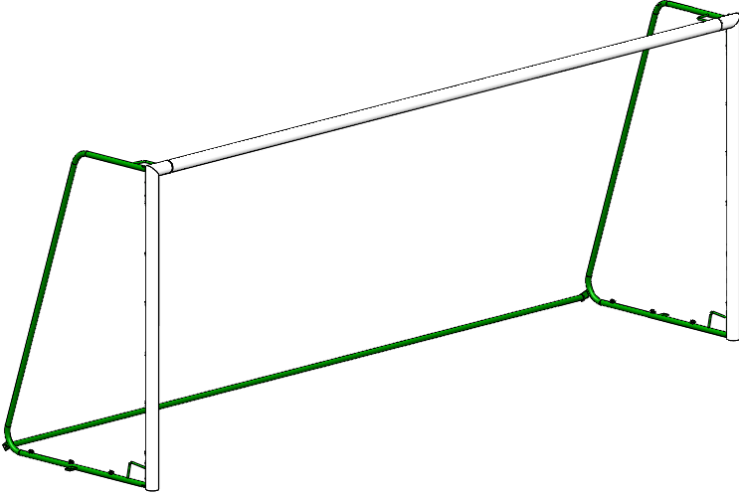

NB: All the dimensions are in millimetres

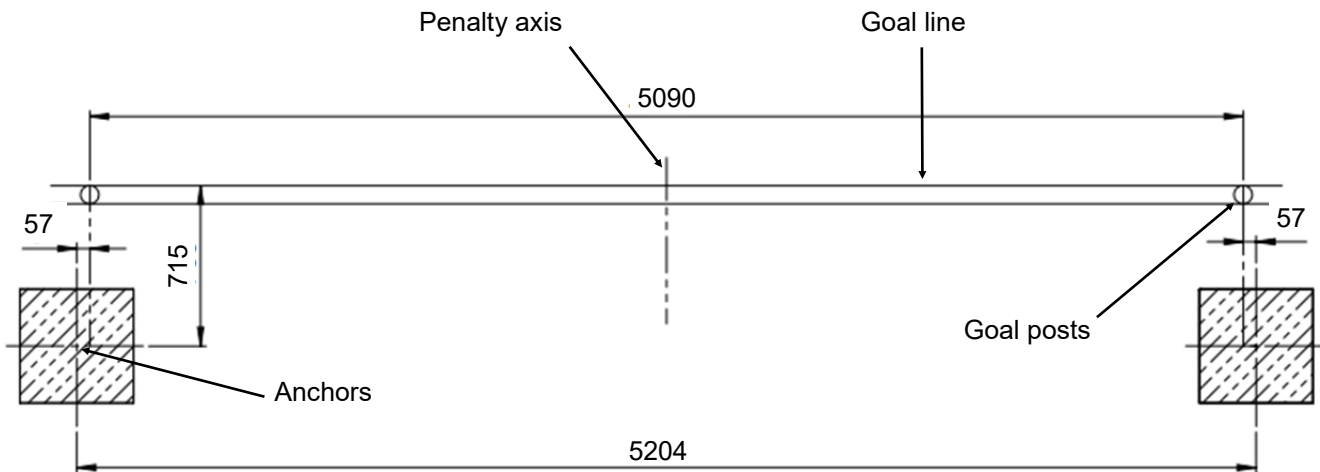
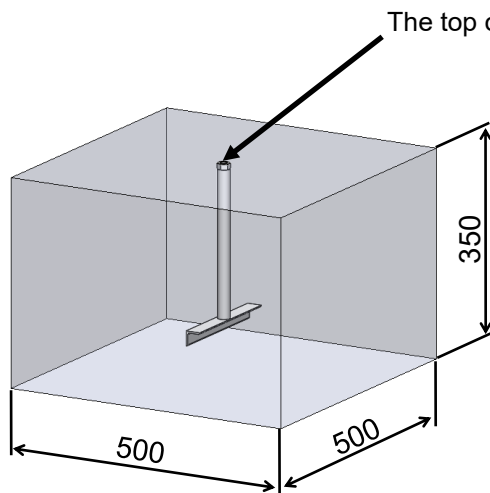

- Dig the holes for the footing of the anchors according to the written dimensions.
- Realize the footing with concret CPJ45 dosed by 350 kg and wait at least 72 hours (6 days during winter).
- To avoid that the concrete come into the anchors put the screw M14x40 on them. Moreover that can allow you to move the anchor.

MONTAGE

NECESSARY TOOLS (NOT INCLUDED)



Wrench 17mm

INCLUDED ITEMS



SS Screws
M10x25

x32



x32

SS Washers 10



x4

Anchor tubes



x4

SS washer 14



x4

Lifting rings

1- ASSEMBLY OF THE CROSSBAR TO THE POSTS (x4)

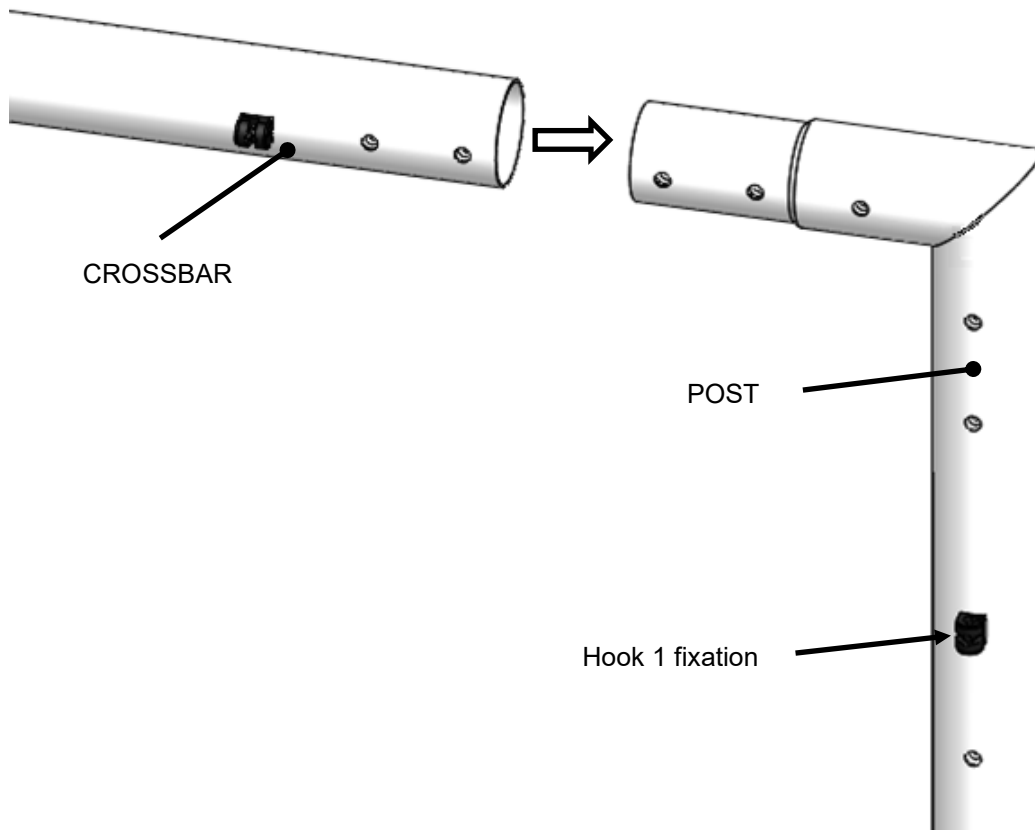

NECESSARY
ITEMS

MONTAGE

2- ASSEMBLY OF THE TOP NET SUPPORT (x4)

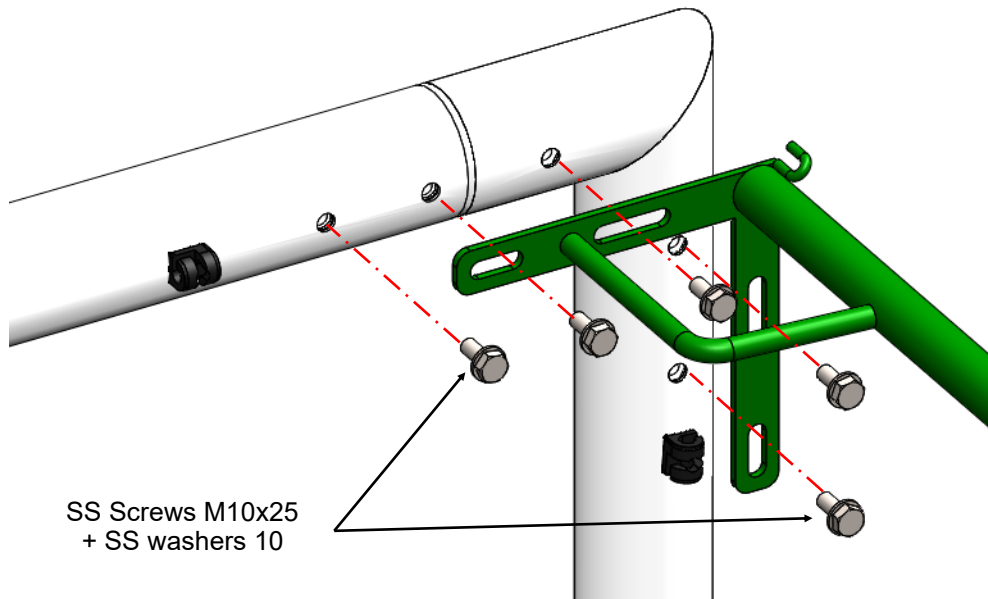

NECESSARY ITEMS



SS Screws
M10x25

x5



SS Washers 10

x5

3- ASSEMBLY OF THE GROUND SIDE BARS (x4)

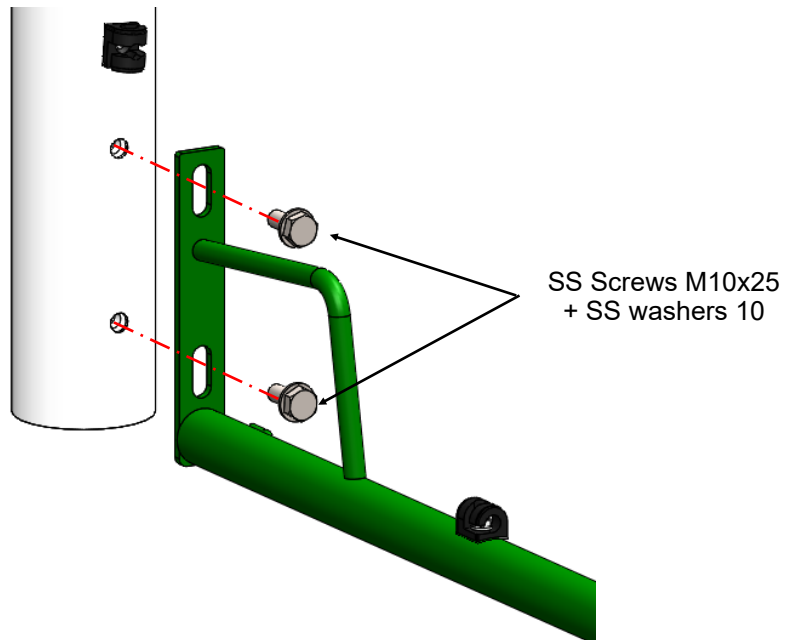

NECESSARY ITEMS



SS Screws
M10x25

x2



SS Washers 10

x2

MONTAGE

4- ASSEMBLY OF THE CONNECTION BAR (x4)

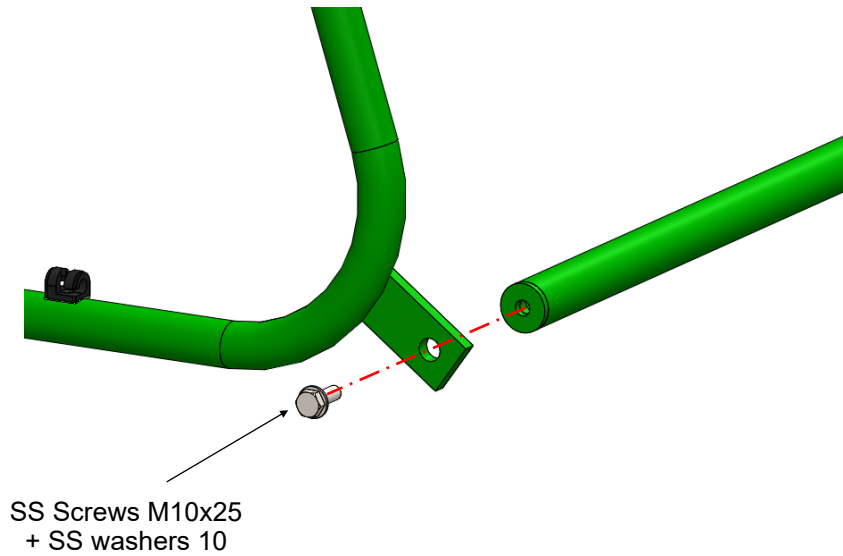

NECESSARY ITEMS

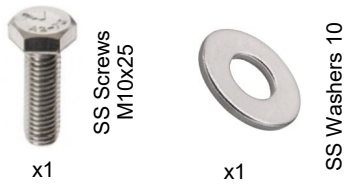

5- FIXATION OF THE GOAL IN THE ANCHORED VERSION (x4)

Position the assembled goal completely over the anchors and position the front post in alignment with the goal line knowing that the post should be flush with the inside of the line ground.

Once positioned, fix the goal using the anchors and lifting rings as shown in the drawing.

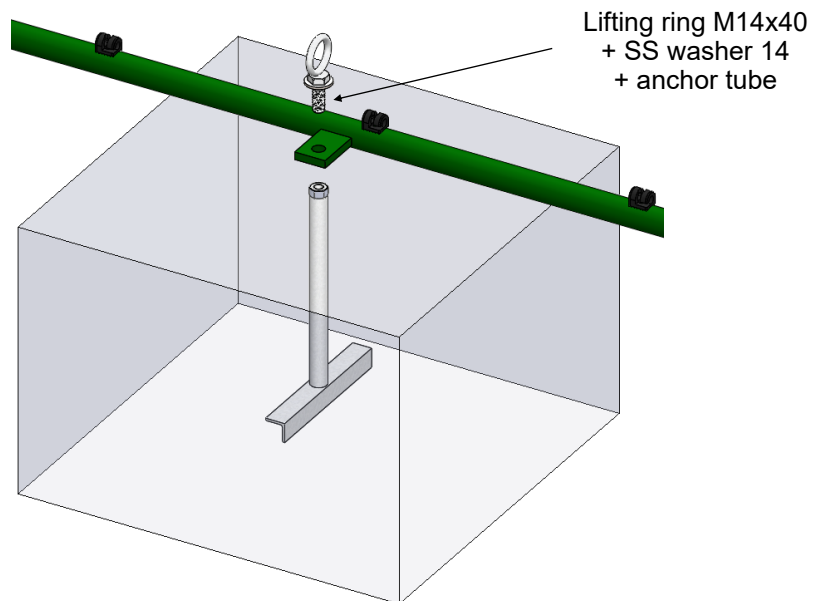







NECESSARY ITEMS



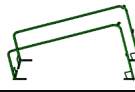
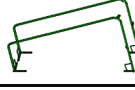

		PACKING LIST		
		2 FOOTBALL GOALS, WITH REAR FRAME, DIMENSION 5x2m		
		PRODUCT REF	S12137 Index G	PAIR



NOMENCLATURE

Pack- age N°	Ref	Index	Designation	Description	Quantity	Packing Method	Weight (kg)	Dim. (mm)
A1	S12101-01	D	Crossbar		1	Plastic bubbles + cardboard 5 layers	23	4850x130x110
A2	S12101-01	D	Crossbar		1	Plastic bubbles + cardboard 5 layers	23	4850x130x110
A3	S12137-02	C	Posts L&R		1 + 1	Plastic bubbles + cardboard 5 layers	23	2200x340x230
A4	S12137-02	C	Posts L&R		1 + 1	Plastic bubbles + cardboard 5 layers	23	2200x340x230
A5	S12033-03 + S12033-04	B + B	Rear cages L&R		1 + 1	Plastic bubbles + cardboard 5 layers	15	2120x1350x300
A6	S12033-03 + S12033-04	B + B	Rear cages L&R		1 + 1	Plastic bubbles + cardboard 5 layers	15	2120x1350x300
A7	S12137-05	A	Connection bar		2	Plastic bubbles + cardboard 5 layers	16	5050x100x50
A8	S12137-09	G	Accessories		1	cardboard 5 layers	3	360x100x100

ACCESSORIES PUT IN A CLEAR PVC BAG

Pack- age N°	Ref	Designation	Description	Qty	Note
A8	BITH1025 + LITA102220	SS Screws M10x25 + SS washers 10		32 + 32	Assembly of the crossbar to the posts
A8	S12471EZ-02	Lifting rings M14x40 + SS washers 14 + Anchor tubes		4 + 4 + 4	Fixation to the ground

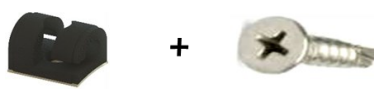
PRE-ASSEMBLED ACCESSORIES

Pack- age N°	Ref	Designation	Description	Qty	Note
A1+ A2+ A3+ A4	S12363 + VITF4819	Hook 1 fixation + Self-tapping screws M4.8x19		64 + 64	Fixed on the goal and the rear frame
A3 + A4	NHBD50100A	Conformity stickers		2	Stuck on the posts

<u>VISA PACKING DEPARTMENT</u>	DATE:
---------------------------------------	-------