

	PRODUCT SHEET					
	ALUMINIUM FOOTBALL GOAL, 3.66x1.83m, MOBILE					
	PRODUCT REF	S12080	PAIR			
						
DESCRIPTION						
Alu structure Ø90 Powder coated 3.66x1.83m						
CONFORM						
European norm EN 748						
ASSEMBLY TIME						
The assembly time for this goal is estimated at 30 minutes with 2 people (without footing).						
TEST AFTER INSTALLATION						
<p>According to the regulation above, this product has to be tested like below:</p> <ul style="list-style-type: none"> - Put 180kg at 20cm from the ground and in the middle of the crossbar for 1min. - Apply an horizontal force of 110 kg on the middle of the crossbar, by a 3 meter rope, for 1min. <p>After these tests, the equipment and the fixation system should not have break, move or show residual deformation.</p> <p>During the first installation, stability and strength tests are compulsory. Every time you install the equipment, a visual check of the stability and strength must be realized. The owner of this equipment must usually control the product.</p> <p>For an optimal use of our products, we advise to follow the installation and maintenance instructions.</p>						
MAINTENANCE						
<p>The equipment has to be regularly maintained by the owner. It is recommended to:</p> <ul style="list-style-type: none"> - Check every week that all the bolts are correctly tightened - Fix paint defects if the unit has been damaged, using the adapted paint specified by the manufacturer. - Replace all damaged or missing parts with a spare part recommended by the manufacturer. - Clean the product by using dishwasher soap, clean water, and soft cloth. 						
WARRANTY						
<p>One full year parts and labour guarantee. Every claim regarding the condition of the delivered equipment has to be done within the warranty period following receipt of the product. The warranty will not apply to:</p> <ul style="list-style-type: none"> - Any degradation during transport. - Any degradation due to poor maintenance. - Any degradation due to use differing from which the product was intended. - Any defect claimed after the end of the warranty period. - Any damage due to a faulty installation or assembly of the product. 						

FIXATION AND FOOTING

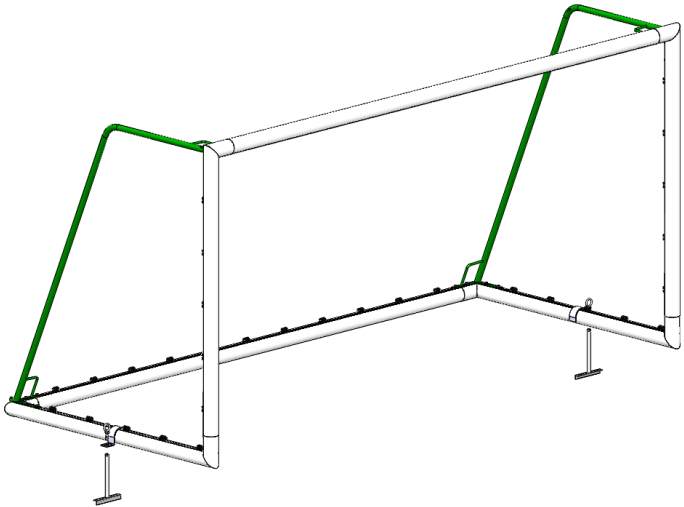

NB: All the dimensions are in millimetres

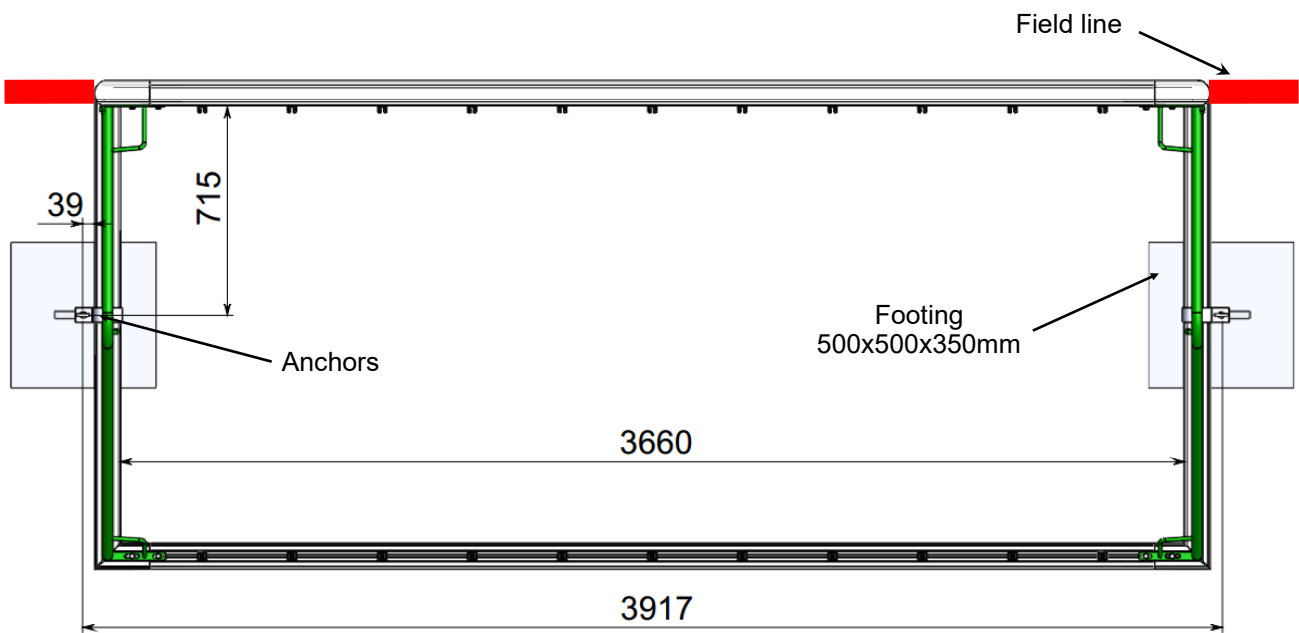
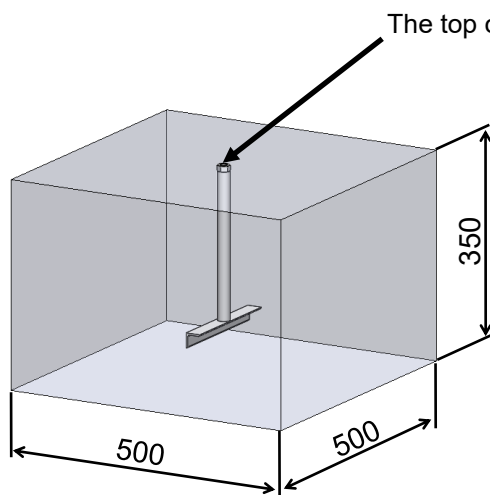

The top of the nut has to be aligned with the ground.

- Dig the holes for the scelling of the anchors according to the written dimensions.

- Realize the footing with concret CPJ45 dosed by 350 kg and wait at least 72 hours (6 days during winter).

- To avoid that the concrete come into the anchors put the screw M14x40 on them. Moreover that can allow you to move the anchor.

ASSEMBLY

NECESSARY TOOLS (NOT INCLUDED)



Wrench 17mm



Allen wrench 6

INCLUDED ITEMS



SS Screws
M10x30

x4



SS Screws
M10x40

x32



SS Washers 10

x32



Anchors

x4



Anchor tubes

x4



SS washer 14

x4



Lifting rings

x4

1- ASSEMBLY OF THE POSTS TO THE CROSSBAR (x4)

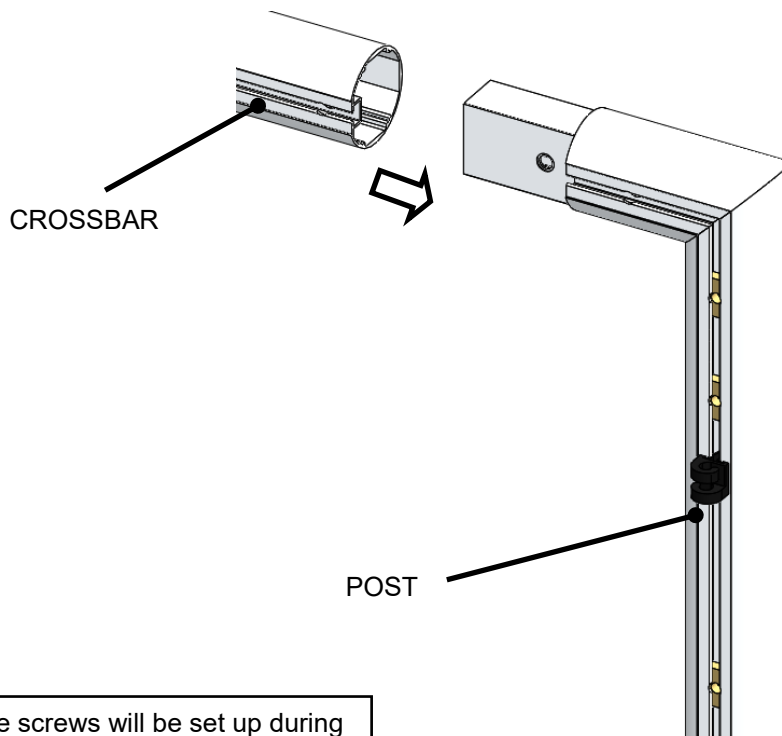

NECESSARY
ITEMS

ASSEMBLY

2- ASSEMBLY OF THE BACK CROSSBARS (x4)

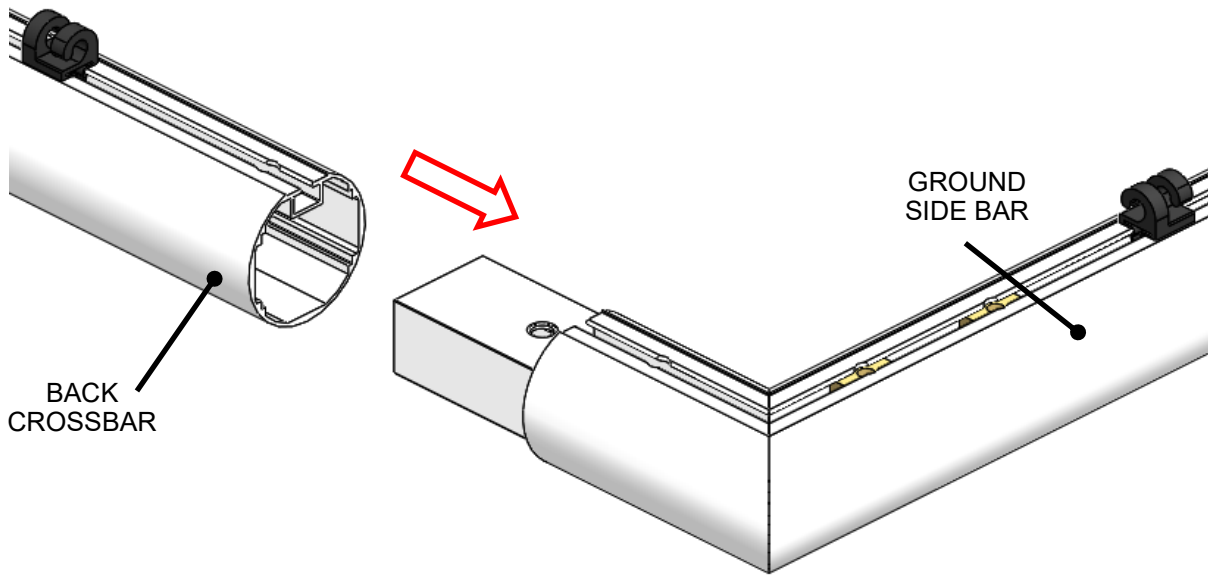

NECESSARY
ITEMS

3 - ASSEMBLY OF THE POSTS TO THE BACK POSTS (x2)

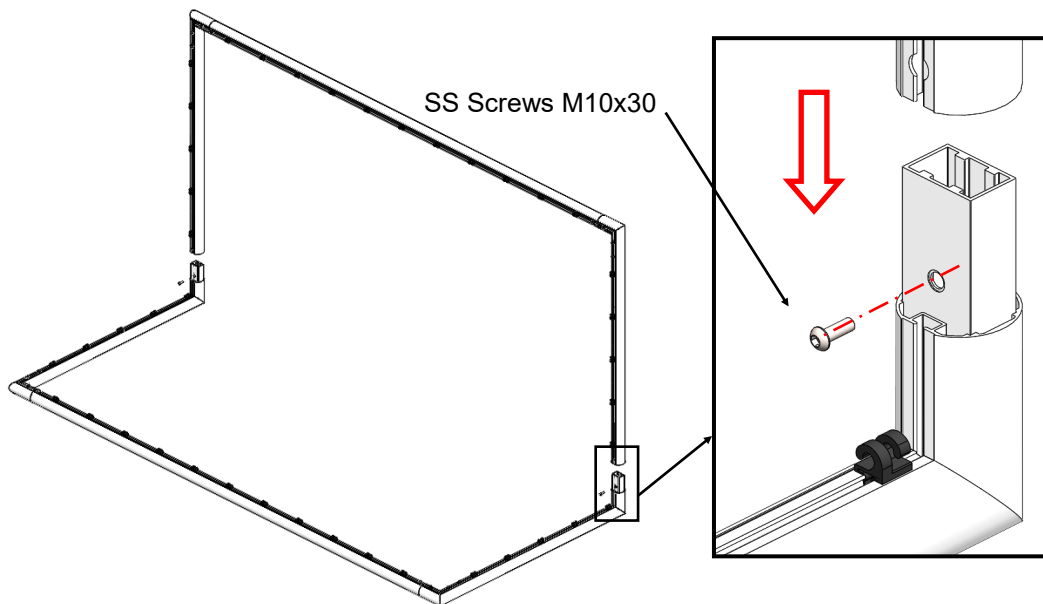

Finger tighten the screws. Once the uprights correctly positioned, you can fully tighten all fasteners. If the screws are too tight in the first step, fixation holes may not line up correctly along the assembly process.

NECESSARY
ITEMS



SS Screws
M10x30

x2

ASSEMBLY

4- ASSEMBLY OF THE SIDE FRAMES (x4)

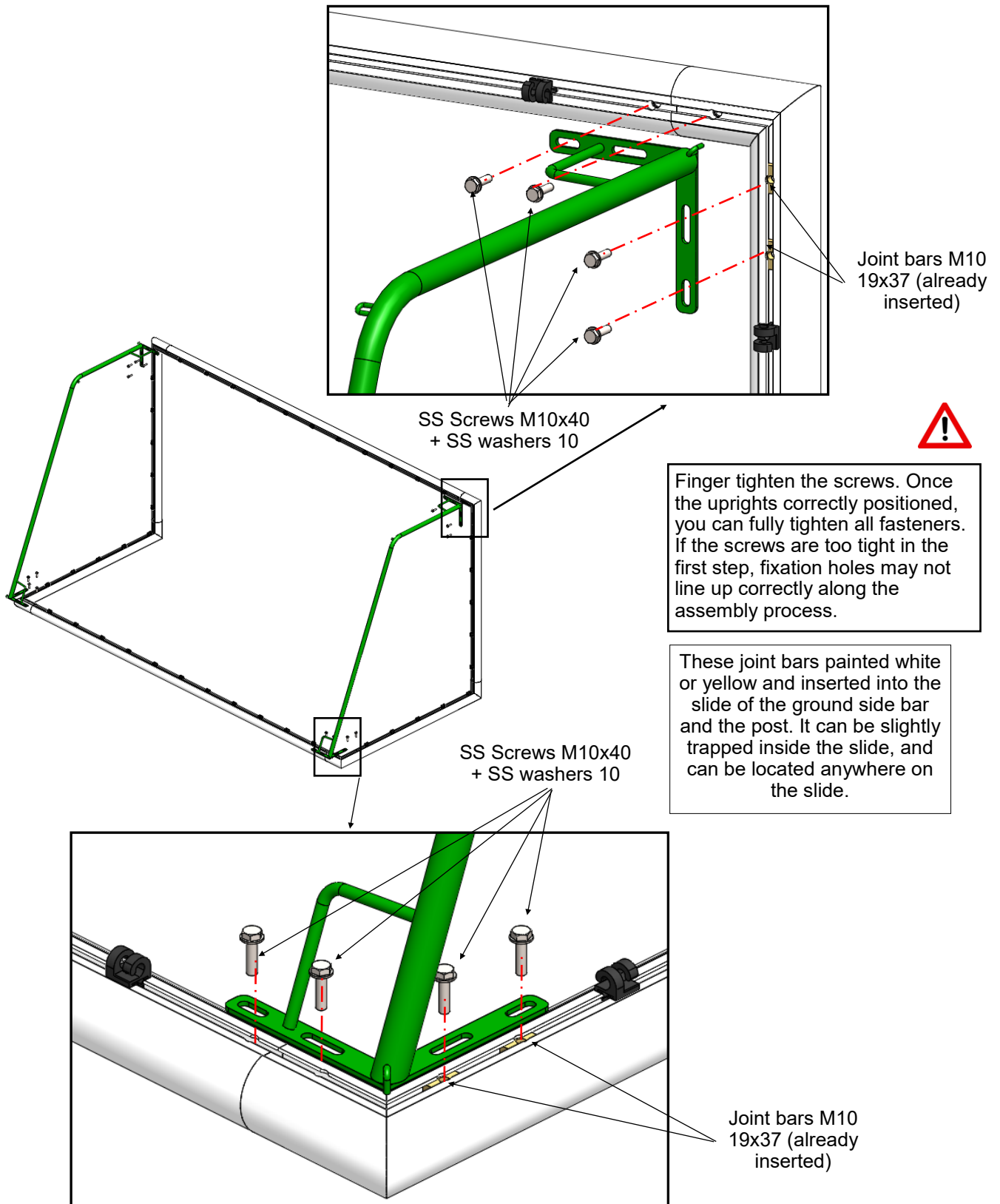

NECESSARY ITEMS



SS Screws M10x40

x8



SS Washers 10

x8

ASSEMBLY

5 - FIXATION OF THE GOAL (x4)

Position the assembled goal completely over the anchors and position the front post in alignment with the goal line knowing that the post should be flush with the inside of the line ground.

Once positioned, fix the goal using the anchors and lifting rings as shown in the drawing.

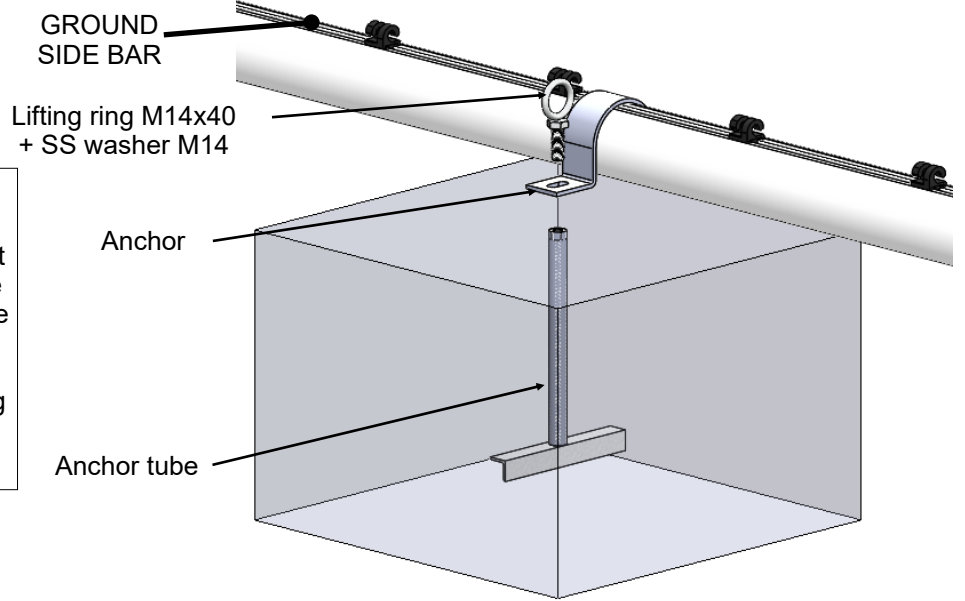



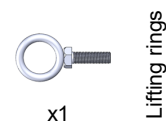
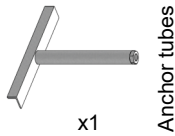
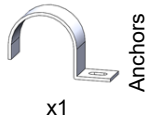







NECESSARY ITEMS





			PACKING LIST		
			ALUMINIUM FOOTBALL GOAL, 3.66x1.83m, MOBILE		
PRODUCT REF		S12080 Index A	PAIR		

NOMENCLATURE



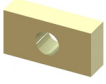

Pack- age N°	Ref	Index	Designation	Description	Quantity	Packing Method	Weight (kg)	Dim. (mm)
A1	S12074-01	A	Crossbar		1	Plastic bubbles + cardboard 5 layers	10	3500x130x110
A2	S12074-01	A	Crossbar		1	Plastic bubbles + cardboard 5 layers	10	3500x130x110
A3	S12074-01	A	Crossbar		1	Plastic bubbles + cardboard 5 layers	10	3500x130x110
A4	S12074-01	A	Crossbar		1	Plastic bubbles + cardboard 5 layers	10	3500x130x110
A5	S12080-02	A	Posts L&R		1 + 1	Plastic bubbles + cardboard 5 layers	11	1760x320x230
A6	S12080-02	A	Posts L&R		1 + 1	Plastic bubbles + cardboard 5 layers	11	1760x320x230
A7	S12174-03	E	Ground side bar L&R		1 + 1	Plastic bubbles + cardboard 5 layers	13.5	1800x430x430
A8	S12174-03	E	Ground side bar L&R		1 + 1	Plastic bubbles + cardboard 5 layers	13.5	1800x430x430
A9	S12080-04	A	Side frame L&R		1 + 1	Plastic bubbles	11	2410x960x250
A10	S12080-04	A	Side frame L&R		1 + 1	Plastic bubbles	11	2410x960x250
A11	S12080-09	A	Accessories		1	cardboard 5 layers	3	300x100x100

PRE-ASSEMBLED ACCESSORIES

Pack- age N°	Ref	Designation	Description	Qty	Note
A5-A8	S12390	Joint bars M10 19x37		16	To fix the rear cages (pre inserted into the rails, and yellow or white colour)
A1-A8	S12364	Hooks 1 fixation		84	Fixed on the goal
A5 + A6	NHBD50100A	Conformity stickers		2	Stuck on the posts

			PACKING LIST		
			ALUMINIUM FOOTBALL GOAL, 3.66x1.83m, MOBILE		
			PRODUCT REF	S12080 Index A	PAIR

ACCESSORIES PUT IN A CLEAR PVC BAG

Package N°	Ref	Designation	Description	Qty	Note
A11	BITK1030	SS Screws M10x30		4	Assembly of the sides ground bar to the post
A11	S12471EZ-02	Lifting rings M14x40 + SS washers 14 + Anchor tubes		4 + 4 + 4	Fixation to the ground
A11	S12475EZ-01	Anchors		4	Fixation to the ground
A11	BITH1040 + LITA102220	SS Screws M10x40 + SS washers 10		32 + 32	Assembly of the crossbar to the posts

<u>VISA PACKING DEPARTMENT</u>	DATE:
---------------------------------------	-------