

|   |   |        |      |
|---|---|--------|------|
|   | <b>PRODUCT SHEET</b>  |        |      |
|   | <b>11m ALU RUGBY GOAL WITH HINGES</b>   |        |      |
|   | PRODUCT REF   | S20118 | PAIR |
|   |  |        |      |
| <b>DESCRIPTION</b>  |   |        |      |
| Alu structure Ø101.6<br>Powder coated<br>5.60 x 11m   |   |        |      |
| <b>CONFORM</b>  |   |        |      |
| European norm<br><b>NF EN 16579</b>   |   |        |      |
| <b>ASSEMBLY TIME</b>  |   |        |      |
| The time to make the assembly of the goal is estimated at 30min at 3 persons (concreting not included). It is recommended to use a lift machine for the installation of the post into the sleeves.  |   |        |      |
| <b>TEST AFTER INSTALLATION</b>  |   |        |      |
| <p>According to the regulation above, this product has to be tested as below:</p> <ul style="list-style-type: none"> <li>- Put 200kg at 20cm from the ground and in the middle of the crossbar for 1min.</li> <li>- Apply an horizontal force of 110 kg on the middle of the crossbar, by a 3 meter rope, for 1min.</li> </ul> <p>After these tests, the equipment and the fixation system should not have a break, move or show residual deformation.</p> <p>During the first installation, stability and strength tests are compulsory.<br/>         Every time you install the equipment, a visual check of the stability and strength must be realized.<br/>         The owner of this equipment must usually control the product. For an optimal use of our products, we advise to follow the installation and maintenance instructions.</p> |   |        |      |
| <b>MAINTENANCE</b>  |   |        |      |
| <p>The equipment has to be regularly maintained by the owner. It is recommended to:</p> <ul style="list-style-type: none"> <li>- Check every week that all the bolts are correctly tightened</li> <li>- Fix paint defects if the unit has been damaged, using the adapted paint specified by the manufacturer.</li> <li>- Replace all damaged or missing parts with a spare part recommended by the manufacturer.</li> <li>- Clean the product by using dishwasher soap, clean water, and soft cloth.</li> </ul> <p>If the forecast planned a bad weather (strong wind,...), the goal should be removed from the sleeves and put on the ground.</p>   |   |        |      |
| <b>WARRANTY</b>   |   |        |      |
| <p>One full year parts and labour guarantee. Every claim regarding the condition of the delivered equipment has to be done within the warranty period following receipt of the product.</p> <p>The warranty will not apply to:</p> <ul style="list-style-type: none"> <li>- Any degradation during transport.</li> <li>- Any degradation due to poor maintenance.</li> <li>- Any degradation due to use differing from which the product was intended.</li> <li>- Any defect claimed after the end of the warranty period.</li> <li>- Any damage due to a faulty installation or assembly of the product.</li> </ul>  |   |        |      |

## FIXATION AND FOOTING

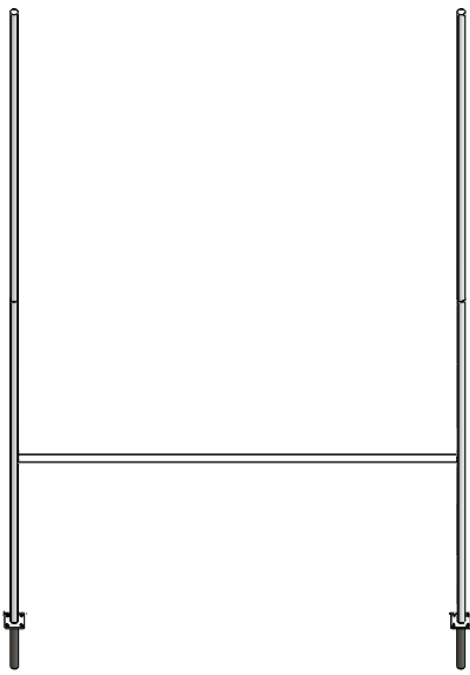
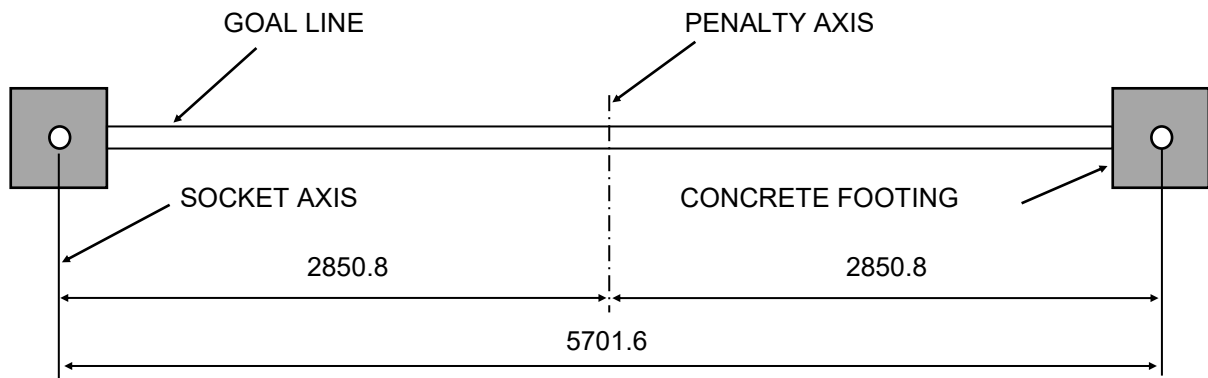

NB: All dimensions are given in millimeters

### OPTION A: Dedicated to single use court

- Dig holes for the concrete blocks according to the dimensions given on figures below. (adapted from **NF EN 16579+AC (August 2019)**)
- Fill the bottom of the holes with CPJ 45 concrete (dosed at 350 kg/m<sup>3</sup>). Put the sockets in position regarding the finished ground level. Adjust the position of the sockets at the specified distances while filling the rest of the holes.
- It is recommended to let the concrete dry for at least 72 hours (depending on the weather).

#### Tips:

Put the goal in position during the drying time of the concrete blocks. Use a plastic film to protect the uprights ends, and put the goal into the sockets. Then use wooden shims to maintain the goal in good position.

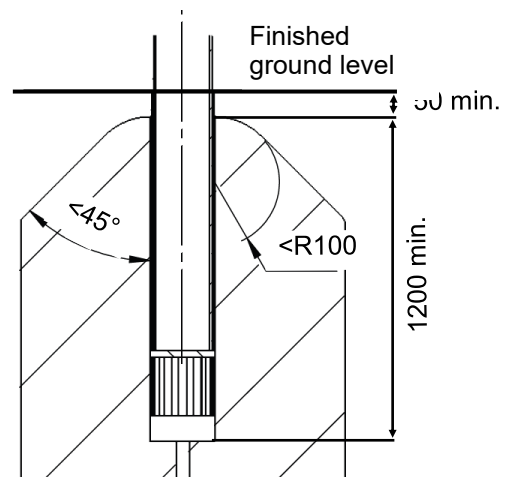
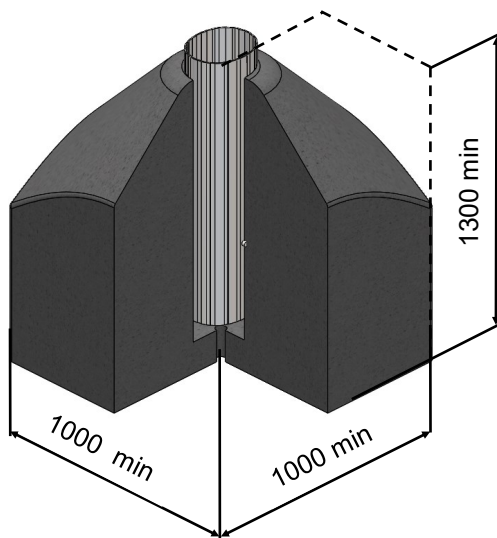

PENETRATION OF THE POST IN THE SOCKET: 800 mm

### OPTION B: Dedicated to multi-sports use court

When the field is used for several sports, it may be necessary to make the footing deeper, in order for the posts and covers to be coated with grass. In this configuration, the way to do must be chosen by the installer, but the minimal dimensions of the concrete block above (1000x1000x1300mm) must be respected.

Such a modification may influence on the height of the crossbar. The adjustment instructions are given at step 2bis.

# ASSEMBLY

 Before the assembly and before putting the posts in the sockets, be sure that the goal is on the field zone and once the goal is in position, check that the runners are positioned outside the field zone.

## NECESSARY TOOLS (NOT INCLUDED)



## INCLUDED ITEMS

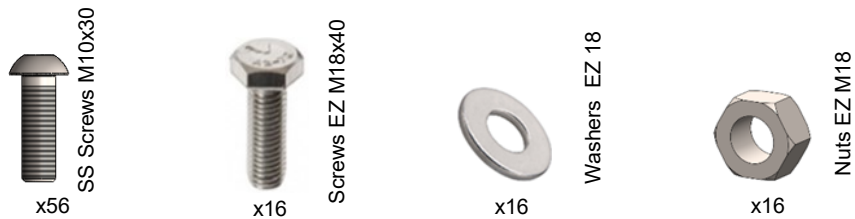

## 1- ASSEMBLY OF THE SLEEVES AND THE ADJUSTMENT BARS TO THE POSTS (x4)

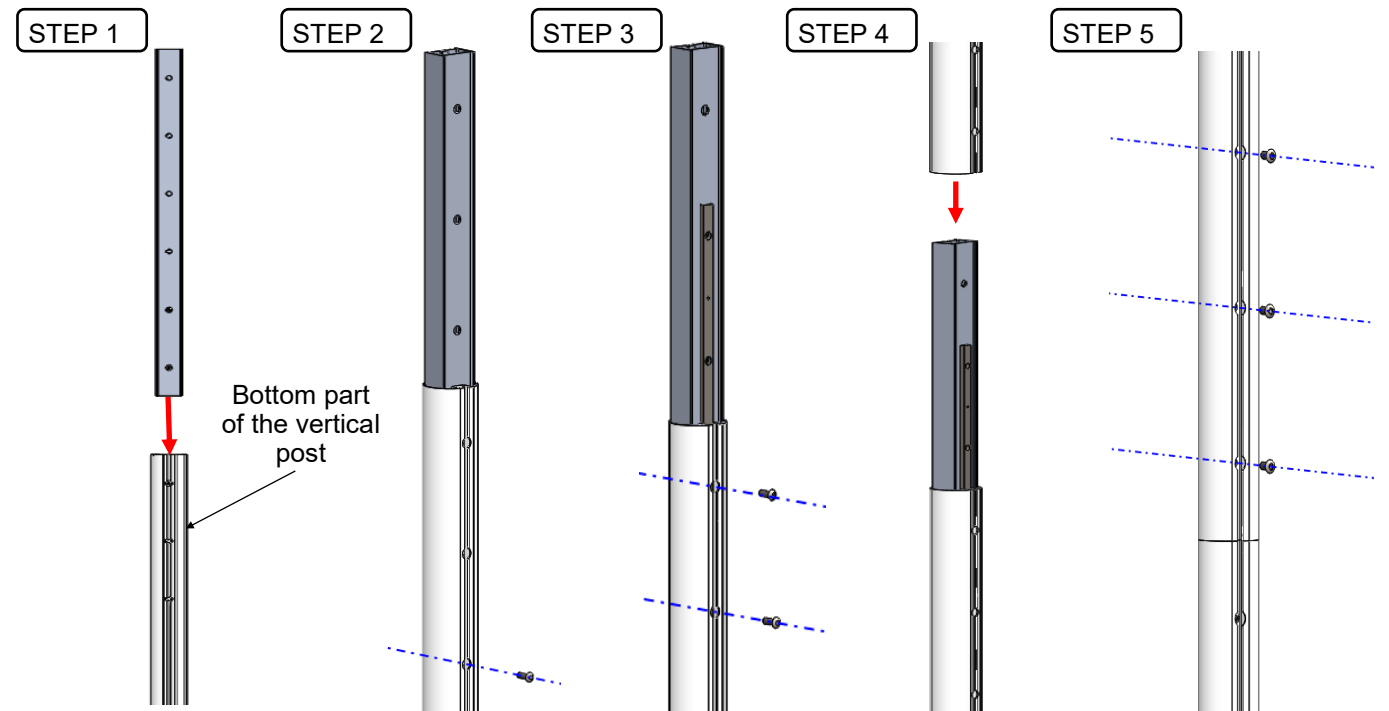

To put the sleeve in the post it is recommended to use a mallet.

 For the steps 2 and 3. Do not tighten firmly the screws. Wait until step 5 to do it.

## NECESSARY ITEMS

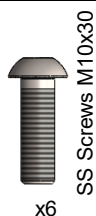

# ASSEMBLY

## 2- ASSEMBLY OF THE CROSSBAR (x4)

STEP 1

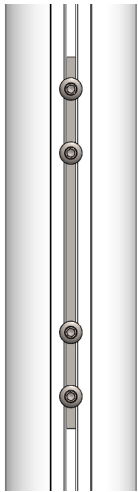

The fixing bar is already inserted in the post slide

Remove the screws from the fixing bar

STEP 2

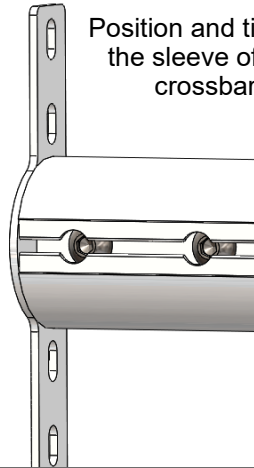

Position and tighten the sleeve of the crossbar

STEP 3

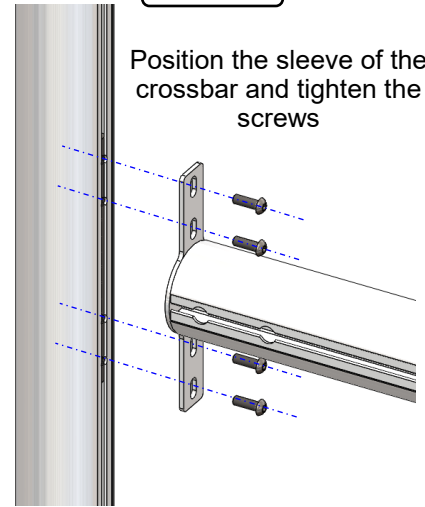

Position the sleeve of the crossbar and tighten the screws

## 2bis- (OPTIONAL) AJUSTMENT OF THE CROSSBAR'S HEIGHT (x2)

When the field is used for several sports, it may be necessary to make the footing deeper. Such a modification may influence on the height of the crossbar.

STEP 1

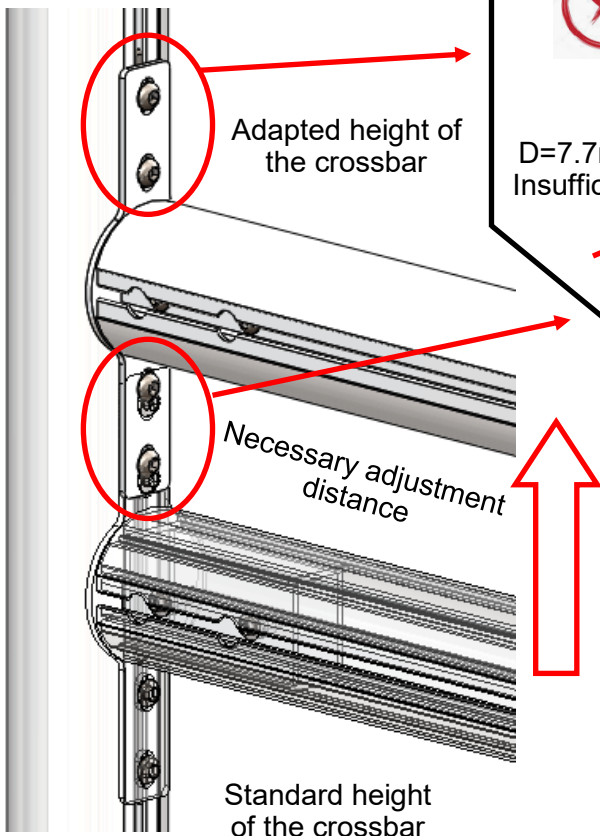

STEP 2

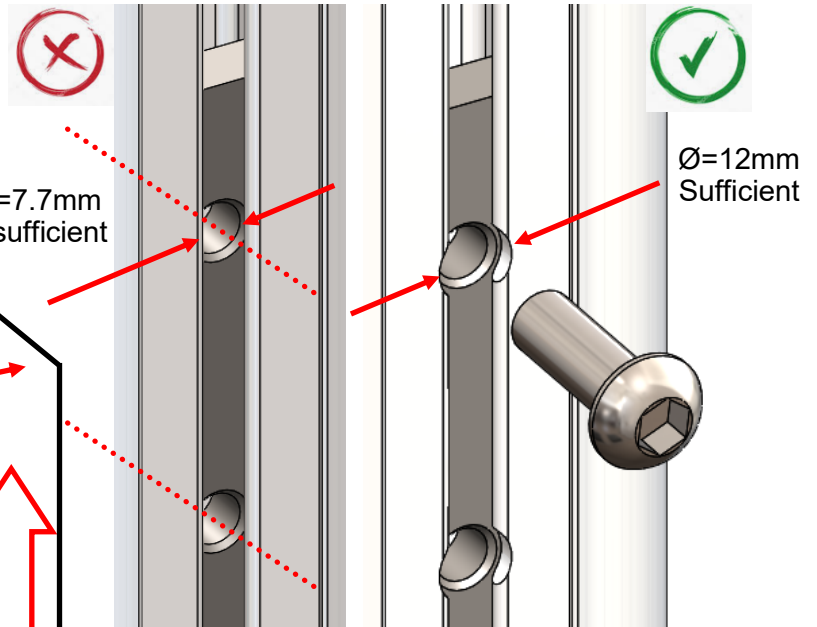

Drill the rail opening at fixation points, in order to allow the bolts to go through. Then go back to step 2.3.

# ASSEMBLY

## 3- ASSEMBLY OF THE HINGES (x4)

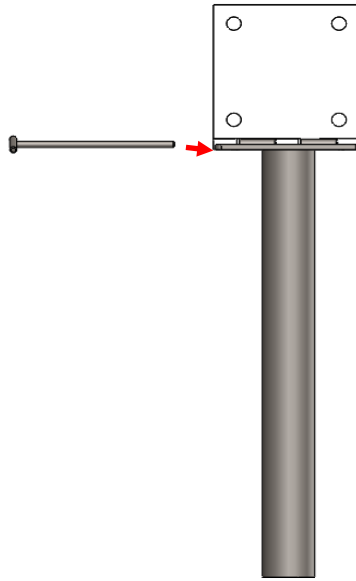

NECESSARY  
ITEMS

## 4- ASSEMBLY OF THE HINGES IN THE SOCKETS (x4)

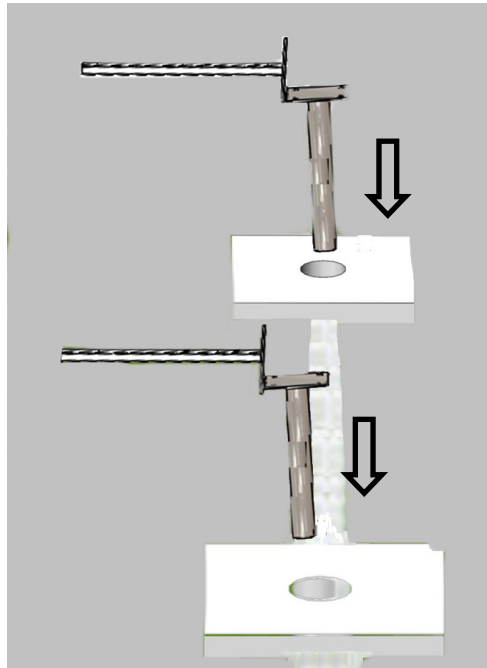

NECESSARY  
ITEMS

# ASSEMBLY

## 5- ASSEMBLY OF THE POST ON THE HINGES (x4)

STEP 1

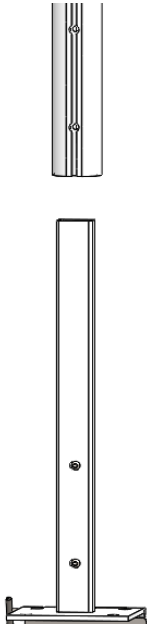

STEP 2

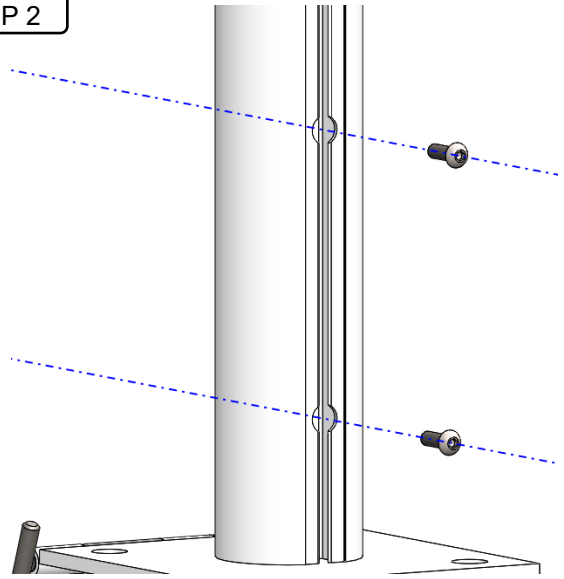

NECESSARY  
ITEMS



SS Screws M10x30  
x2

## 6- FIXATION OF THE HINGES (x4)

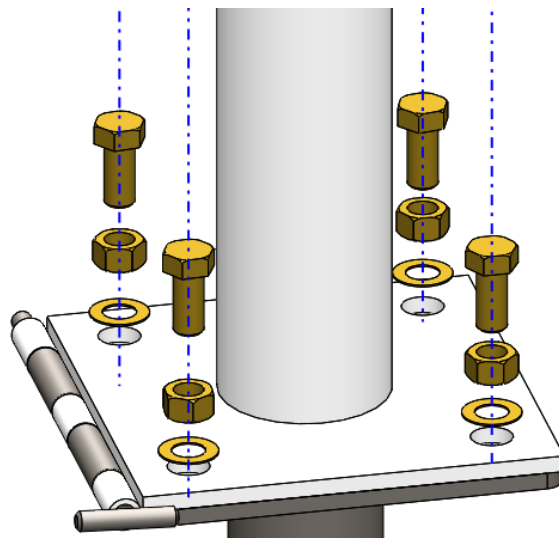

NECESSARY  
ITEMS



x4

Screws EZ M18x40



x4

Washers EZ 18



x4

Nuts EZ M18

# ASSEMBLY



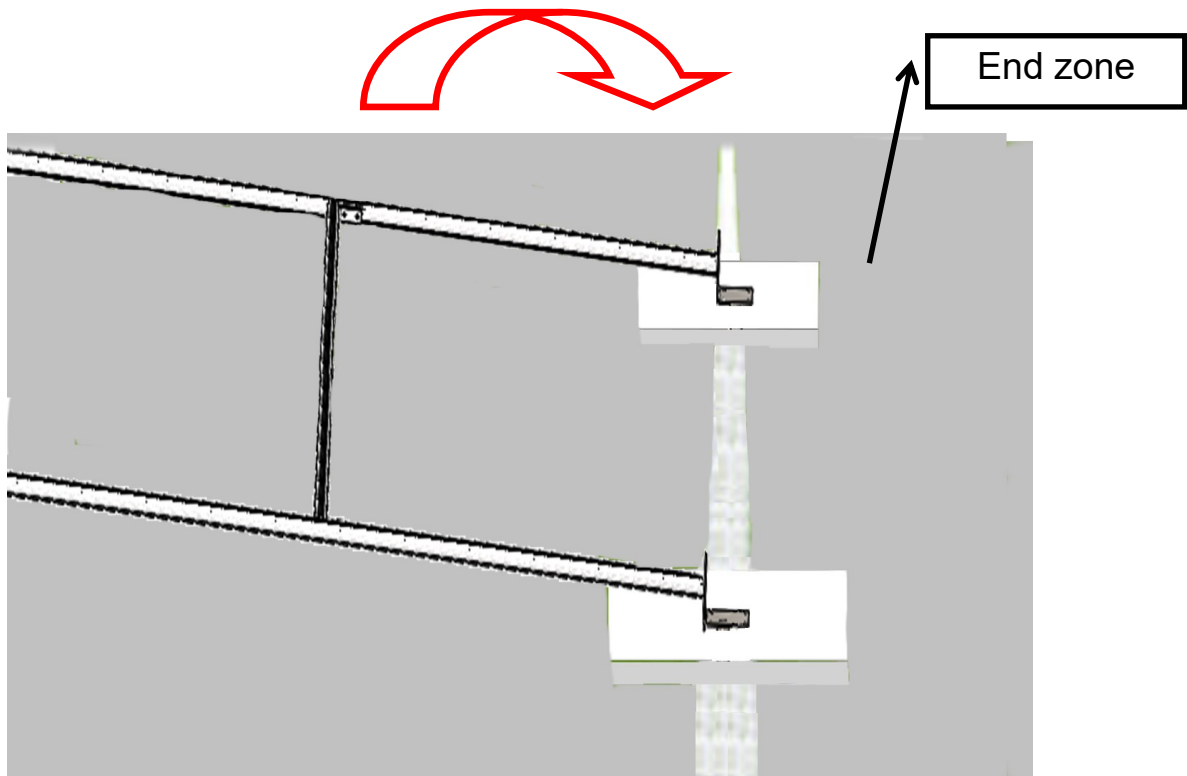

## 7- ASSEMBLY OF THE POSTS THANKS TO THE HINGES (x2)





INSTALLATION OF THE HINGES IN THE SOCKETS: 800 mm

|                                       |  |                |                     |      |  |
|---------------------------------------|--|----------------|---------------------|------|--|
|                                       |  |                | <b>PACKING LIST</b> |      |  |
| <b>11m ALU RUGBY GOAL WITH HINGES</b> |  |                |                     |      |  |
| PRODUCT REF                           |  | S20118 Index H |                     | PAIR |  |

**NOMENCLATURE**

| Package N° | Ref                      | Index | Designation                           | Description   | Quantity  | Packing Method                       | Weight (kg) | Dim. (mm)    |
|------------|--------------------------|-------|---------------------------------------|---|-----------|--------------------------------------|-------------|--------------|
| A1         | S20082-01                | C     | Crossbars                             |    | 2         | Plastic bubbles + cardboard 5 layers | 26          | 5650x240x120 |
| A2         | S20118-02+<br>S20082-05b | C + C | Upper and bottom post+<br>Fixing bars |    | 1+1+1     | Plastic bubbles + cardboard 5 layers | 25          | 6000x230x130 |
| A3         |                          |       |                                       |   | 1+1+1     |                                      | 25          | 6000x230x130 |
| A4         |                          |       |                                       |   | 1+1+1     |                                      | 25          | 6000x230x130 |
| A5         |                          |       |                                       |   | 1+1+1     |                                      | 25          | 6000x230x130 |
| A6         | S20082-03+<br>S20082-05a | C + C | Sleeves+<br>adjustment bars           |   | 4+4       | Plastic bubbles                      | 13          | 1250x170x130 |
| A7         | S20088-04                | F     | Upper + lower hinges +<br>hinge axle  |  | 1 + 1 + 1 | Plastic bubbles                      | 20          | 900x300x300  |
| A8         |                          |       |                                       |   | 1 + 1 + 1 |                                      | 20          | 900x300x300  |
| A9         |                          |       |                                       |   | 1 + 1 + 1 |                                      | 20          | 900x300x300  |
| A10        |                          |       |                                       |   | 1 + 1 + 1 |                                      | 20          | 900x300x300  |
| A11        | S20082-06                | C     | Crossbar sleeves                      |  | 4         | Plastic bubbles                      | 12          | 1100x350x280 |

**PRE-ASSEMBLED ACCESSORIES**

| Package N° | Reference                           | Designation  | Description  | Qty          | Note  |
|------------|-------------------------------------|--|--|--------------|---|
| A2-A11     | BITK1030                            | SS Screws M10x30                                     |   | 56           | To fix the sleeves,<br>adjustment bars and<br>posts |
| A7-A10     | BTKH1840W<br>LTKA183430W<br>TTKC18W | Screws EZ M18x40 +<br>Washers EZ 18 +<br>Nuts EZ M18 |  | 16 + 16 + 16 | To fix the hinges                                   |
| A2-A5      | NHRB50100A                          | Conformity stickers                                  |   | 4            | Stuck on the posts                                  |

|                                |       |
|--------------------------------|-------|
| <b>VISA PACKING DEPARTMENT</b> | DATE: |
|--------------------------------|-------|